



# MARK V 520 UPGRADE PKG

## 555771

### Tools Needed

- ◆ 7/16 Open end Wrench
- ◆ 5/32 Allen Wrench
- ◆ Alignment Gauges (supplied)

## SAFETY

### WARNING

**Before performing the conversion of your saw table to the Pro Fence 520 saw table and fence system, do the following:**

- **Read and understand, and follow ALL the Assembly & Alignment procedures enclosed herein.**

### CONVERSION INSTRUCTIONS

1. Remove your saw table, extension table, and floating tables from your Mark V Model 510, turn the tables upside down on a flat smooth surface. Using a 7/16" open end wrench remove the keps nuts (515294) and the flat washers (120392) from the mounting studs of the steel table tubes (514667). Remove the tubes, spacers (514101) and jack screws (514440) from all your tables.

### NOTE

**Save the keps nuts (515294) and flat washers (120392) for use in attaching the new extrusions to the saw table.**

**Refer to the exploded views on Page 3 for part references.**

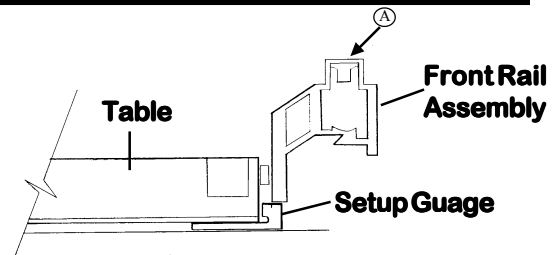

Figure A-1

2. With your table upside down on a flat smooth surface, slide the setup gauge (25) under the front edge of the saw table near the table's center, the thick part should stick out from under the front and up toward the underside of the table (See Figure A-1).
3. Insert the flat head screws (23) through the front rail assembly (17) from the front, slide the spacer (24) on the screw and slide the screws through the tube mounting holes in the table.
4. Place the flat washer (120392) on the screw and then the keps nut (515294). Finger tighten only. Make sure the setup gauge (25) is flat against the surface of your table and against the front rail assembly and tighten nuts securely.

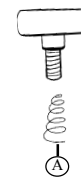

Figure A-2

5. Slide the small diameter end of the spring (22) over the knob (21) (See Figure A-2). Thread the knob with the spring into the threaded inserts near each end of the rail assembly (Marked A in Figure A-1).
6. Repeat steps 2, 3, 4, and 5 for the rear rail assembly (19) on the main saw table.

- Repeat steps 2 through 6 for your extension table and floating tables. Then mount the tables back on your MarkV.

### **ALIGN THE PRO FENCE PARALLEL WITH THE WORKTABLE**

- Place the miter gauge in the left slot of the worktable on the infeed side. Place the Pro Fence on the right side of the saw table.
- Insert the long 5/32" Allen wrench through the miter gauge and secure it using the short 5/32" Allen wrench and a set screw borrowed from the tool rest.
- Move the fence toward the Allen wrench until it just touches it.
- Lock the lower fence lock handle first, then lock the upper fence lock handle to secure both ends of the pro fence.
- Slide the miter gauge back and forth in the slot. The tip of the Allen wrench should keep in slight contact with the fence. Watch that you don't scratch the fence.
- If the allen wrench pulls away from or binds against the fence, the fence needs aligning. If so, do the following:
  - Using the short 5/32" short Allen wrench, loosen the four button head cap screws (3), located on the top of the fence, slightly. They should be just tight enough to require firm pressure to align the fence.
  - Raise the upper fence lock handle only to unlock the rear of the fence.
  - Adjust the rear end of the fence so that it just touches the allen wrench as the miter gauge slides along the fence.

- When alignment is reached, lock the upper fence lock handle. Slide the miter gauge back and forth to double check your alignment. Using the short 5/32" Allen wrench, tighten the four button head cap screws (3) completely.

### **ASSEMBLE THE FENCE STRADDLER**

- See the exploded view on Page 3. Unscrew the fence straddler's knob (28) and remove the washer (30), machine screw (29), and slide rail (27) from the fence straddle block (26).
- Transfer the slide rail (27) to the other side of straddle block and reassemble with the screw, washer and knob, as shown in Figures A-4 and A-5.

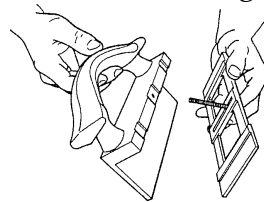

Figure A-4

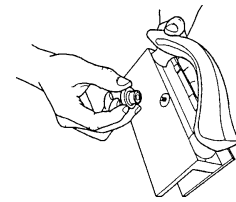

Figure A-5

### **USING THE FENCE STRADDLER**

- Use the fence straddler to hold down and push stock narrower than 1-1/2" past a saw blade or cutter. The straddle block (26) sits over the fence, while the bottom edge of the slide rail (27) holds down on the stock. To change the height of the slide rail (27), loosen the knob (28). To reverse the slide rail (27) loosen the knob (28) and rotate the slide rail (27) 180°. Adjust the bottom edge of the slide rail (27) firmly on the stock (See Figure A-3). Then tighten the knob (28).

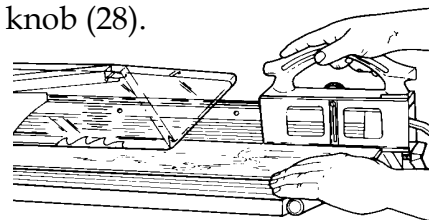
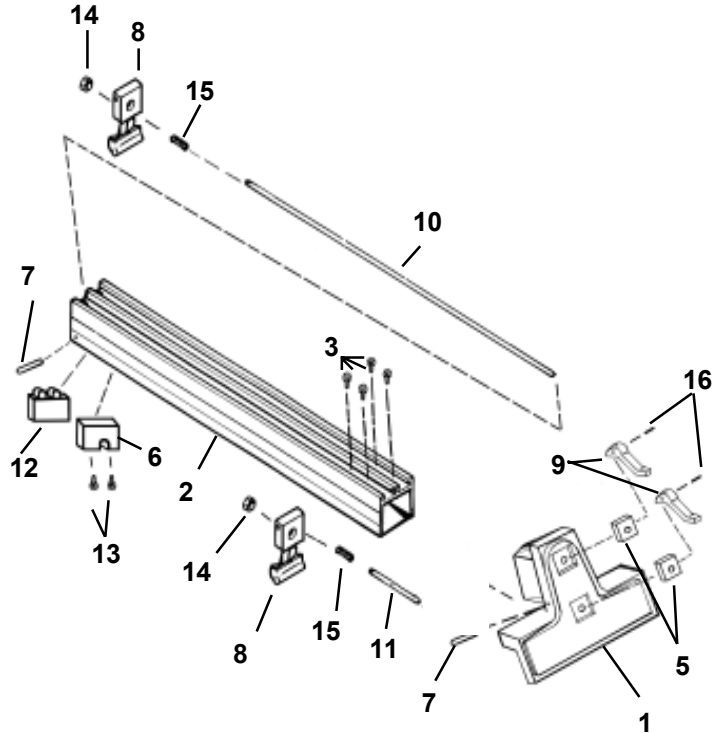

Figure A-3

## PRO FENCE

Ref. No.	Part No.	Item Description	Qty.
—	518418	<b>Pro Fence Assembly</b> (Incl. 1-17)	
1	518419	. Fence Base .....	1
2	518400	. Fence Extrusion .....	1
3	517829	. Screw 1/4-20x1/2 Button Hd .....	4
4	518404	. Front Pad (not shown) .....	4
5	514317	. Plate-wear .....	2
6	518420	. Spring Block .....	1
7	518405	. Locking Bar Rod .....	2
8	518407	. Locking Bar .....	2
9	521578	. Locking Handle .....	2
10	518410	. Rod-Long .....	1
11	518409	. Rod-Short .....	1
12	518423	. Rear Pad .....	1
13	518461	. Screw #10-24 Flat Hd .....	2
14	518459	. Lock Nut .....	2
15	518416	. Spring .....	2
16	514527	. Rollpin .....	2



## SAW TABLE CONVERSION KIT

Ref. No.	Part No.	Item Description	Qty.
17	518488	Front Rail Asm. - Main Table .....	1
18	518489	Front Rail Asm. - Ext Tables .....	3
19	518490	Rear Rail Asm. - Main Table .....	1
20	518491	Rear Rail Asm. - Ext Tables .....	3
21	515859	Knob w/stud .....	8
22	518462	Spring .....	8
23	518460	Flat Head Screw .....	18
24	518403	Table Spacers .....	18
25	521097	Alignment Guage .....	2

## FENCE STRADDLER

Ref. No.	Part No.	Item Description	Qty.
—	521107	<b>Fence Straddler Assembly</b> (incl. 26-30)	
26	521106	.. Straddle Block .....	1
27	513706	.. Slide Rail .....	1
28	513713	.. Knob .....	1
29	521418	.. Machine Screw .....	1
30	513864	.. Washer .....	1

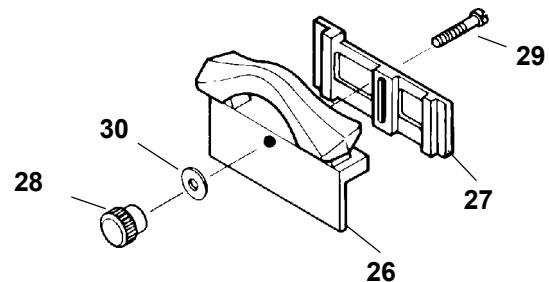

---

# NOTES

---

