



DC-6000 Dust Collector

556700



WARNING

Read the SAFETY section and Complete the ASSEMBLY procedures before operating the Shopsmith Dust Collector.

Table of Contents

Parts List	2
Introduction/Safety	4
General Information	7
Assembly	8
Maintenance and Troubleshooting	13

Parts List

Ref. No.	Part No.	Item Description	Qty.	Ref. No.	Part No.	Item Description	Qty.
1	556710	Filter Hood	1	28	518393	Retaining Strap Assembly	1
—	514809	Retaining Strap Asmy. (Incl. 2-4)	1	29	523094	Collection Bag	1
2	514856	Strap, Silver	1	30	514831	Hex Head Cap Screw, 1/4-20x1-1/2"	4
3	514966	Rack	1	31	120380	Spring Lock Washer, 1/4"	4
4	514855	Clamp	1	32	514896	Rear Handle	1
5	515689	Main Housing w/Warning Label	1	33	522388	Switch	1
6	515561	Self tapping Screw	4	34	515547	Leg Cap, Right	1
7	515534	Support Bracket	1	35A	515552	Wiring Harness	1
—	556701	Motor & Blower Asmy. (Incl. 8-20).....	1	35B	522323	Wire Cover	1
8A	515549	Inlet Seal	1	35C	515555	Self-Tapping Screw	1
8B	523172	Union Connector	1	36	515546	Right Leg	1
9	523190	Screw, M5-0.8x10	12	37	515554	Leg Cap, Left	1
10	523196	Fan Housing	1	38	515664	Left Leg	1
11	523201	Socket Head Cap Screw, M6-1x20 LH	1	39	51481208	Snap-In Plug	8
12	523200	Spring Washer, M6-IDx40mm	1	40	515138	Truss Head Screw	14
13	523199	Turbo Fan	1	41	120214	Lock Washer	14
14	523205	Hex Head Cap Screw, M8-1.25x10	4	42	102634	Nut, 5/16-18	14
15	523187	Lock Washer, M8	4	43	514807	Wheel Retainer	2
16	5155350	Motor Housing	1	44	514806	Wheel	2
17	557087	Square Key, 5mm x 5mm x 30	1	45	514755	Wheel Shaft	1
18	556701	Motor w/plug	1	46	51478902	Base Pan	1
18A	515563	Connector	1	47	514805	Caster	2
18B	515586	Strain Relief	2	—	514929	Inlet Pug Assembly (Incl. 50-51)	2
18C	514881	Screw	2	48	514824	Inlet Plug	2
18D	557061	Capacitor	1	49	514928	Cap	2
19A	515550	Motor Seal	1	50	300004	Hose	1
19B	518333	Short Seal	1	51	515670	Power Cord	1
20	515137	Self-tapping Screw	2	52	515126	Star Washer	2
21	514832	Self-Tapping Screw, 10-16x1/2"	4	53	513897	Hex nut, #10-32	2
22	514817	Cover Plate	1	54	523086	Handle Spacer	2
23	515562	Self-Tapping Screw	4				
24A	51476702	3-way Inlet	1				
—	521769	Handle Package (Incl. 24B & 24C)	1				
24B	521761	Handle	1				
24C	521762	Screw	2				
25	515555	Self-Tapping Screw	6				
26	515553	Cable Clip	1				
27	515219	Bag Clip	3				

Manufacturer: Shopsmith
 6530 Poe Avenue
 Dayton, Ohio 45414
 937-890-5197

Part Number: 556700
 Description: Shopsmith Air Filtration System DC-6000

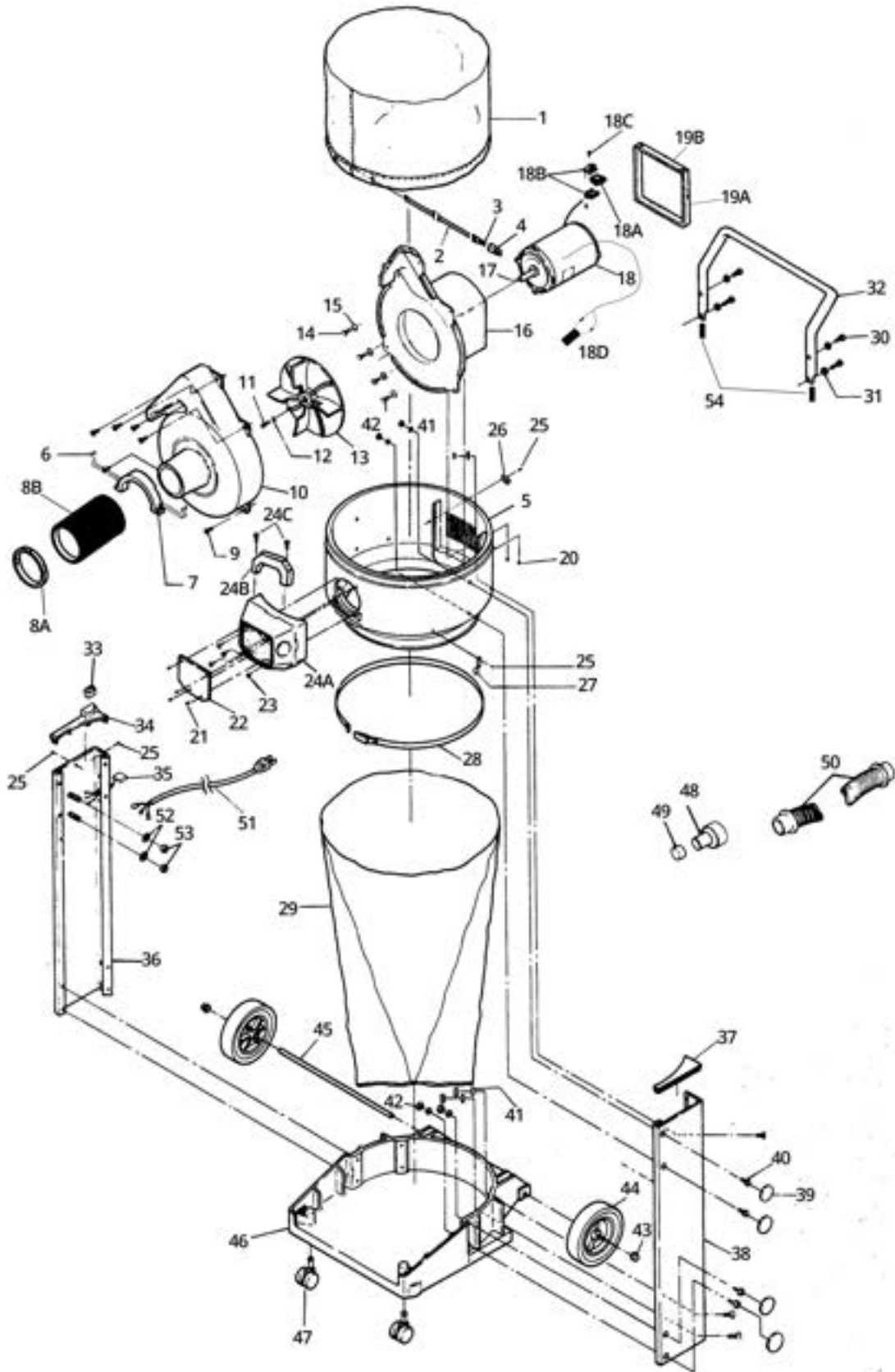

Figure 1

Introduction/Safety

Dust Free Woodworking

The Shopsmith Air Filtration System provides an efficient and effective means to collect wood shavings and dust from the workshop. Unlike conventional shop vacuums, the Dust Collector is designed to collect and filter the large volume of dust and shavings produced with modern woodworking equipment. When used in conjunction with efficient dust collection chutes and attachments, the Dust Collector will help you approach “dustfree” woodworking.

Airflow is the Key

The “heart” of the Shopsmith Dust Collector is a large industrial blower which moves large volumes of air. The dust and shavings pass through the blower, are slowed down, and then settle in the disposable bag. The air is then returned to the room after passing through a large, permanent filter capable of filtering even the smallest wood dust particles.

As you put your hand over the end of the hose you will not feel the high vacuum, or sealed suction, of a home or shop vacuum. A home vacuum cleaner needs this sealed suction to move air through small openings. A shop vacuum also requires a high sealed suction when used for water pick-up. The large airflow of the Shopsmith Dust Collector can be “observed” by placing a few fingers into the end of the hose. The airflow of the Shopsmith Dust Collector is much higher than any home or shop vacuum.

Safety First

The Shopsmith Dust Collector has many built-in safety features. But, the effectiveness of these features depends on you. Throughout

this manual, we list WARNINGS, CAUTIONS, and NOTES. We advise that when you come to one of these listings, please read and understand it fully. Their meanings are:

WARNING

A WARNING is given when failure to follow the directions could result in injury, loss of limb, or life.

CAUTION

A CAUTION is given when failure to follow the directions could result in temporary or permanent damage to the equipment.

NOTE

A NOTE is used to highlight an important procedure, practice or condition.

WARNING

General Safety Rules for Power Tools

- **Read and understand the Owners Manual.**
- **Ground all tools (unless double insulated).**
- **Wear proper eye and ear protection. Also, wear a dust mask.**
- **Do not use power tools in damp, wet or explosive atmospheres.**
- **Keep work areas well lit, clean, and free from clutter.**
- **Repair or replace damaged parts before further use. If a strange noise or vibration develops, turn off and unplug the machine. Correct the problem.**
- **Do not overreach. Keep proper footing and balance at all times.**

- Do not leave the tool running unattended. Turn power off. Don't leave tool until it comes to a complete stop.
- Avoid unintentional starting. Make sure the switch is in the "off" position before plugging in or unplugging the tool.

Safety Rules for the Shopsmith Dust Collector

- Read and understand the Owners Manual. Learn the Dust Collector's applications and limitations as well as the specific potential hazards peculiar to it.
- Ground the Dust Collector. The collector comes equipped with an approved 3-conductor cord and a 3-prong grounding type plug to fit the proper grounding type receptacle, the green conductor in the cord is the grounding wire. Never connect the green wire to a live terminal.
- Avoid dangerous environments. Electric shock could occur if the Dust Collector is used on wet surfaces. Do not expose it to rain, snow or wet floors. Store it indoors.
- Do not operate the Dust Collector without the 3-way inlet securely mounted in place. The airflow can pull body parts into the intake opening and into contact with the fan.
- Do not pick up water or wet materials with the Dust Collector.
- Position the hose(s) out of the way so you won't trip over them. Do not pick up hot or burning materials such as cigarettes and ashes. They could ignite a fire in the bag. These materials should be properly disposed of in a fireproof container.
- Do not leave the Dust Collector running unattended.
- Do not attach the Dust Collector or hoses to a tool used for metal grinding or sharpening. Sparks generated during grinding could ignite dust and shavings inside the bag. They may also damage the hose and the fittings.
- Do not reach across a power tool to turn off the Dust Collector. Turn off the power tool and then go around to the Dust Collector and turn it off.
- Do not force the Dust Collector to do a job for which it was not designed.
- Check damaged parts. A damaged part should be properly repaired or replaced before further use. If a strange noise or vibration develops, immediately turn off the power, unplug the Dust Collector and correct the problem.
- Avoid unintentional starting. Make sure the switch is in the "Off" position before plugging in or unplugging the Dust Collector.
- Turn off and unplug the Collector before changing bags, and performing maintenance and service.
- Do not stand or lean on the Dust Collector. You could fall onto the Collector or it could tip over injuring you and/or damaging the Collector.
- Maintain the Dust Collector. Keep the Dust Collector maintained according to the Owners Manual.
- Use only recommended Shopsmith parts and accessories on your Dust Collector. NEVER use non-Shopsmith replacement parts or accessories. Using non-Shopsmith parts may cause a hazardous condition and will void your warranty.
- Do not drag the cord across sharp tools or edges which could damage the cord. Do not try to move or unplug the Dust Collector by pulling on the cord.

Sawdust and Shavings

Sawdust and shavings can be fire hazards and breathing dust can be a health hazard for some people. Dust may cause physical discomfort, especially if you have emphysema, asthma, or an allergic reaction. The dust from some woods can create a toxic reaction.

Attach the Dust Collector to the dust chutes on your power tools. This will help collect most of the sawdust and shavings while you're working and prevent them from entering the air in the room.

Electrical Requirements

This powerful Dust Collector draws a substantial amount of starting current. Therefore, it should not be run on the same circuit as the Shopsmith MARK 7 or Mark V as you could over-load the circuit.

Before starting the Dust Collector, attach hose(s) and set up as intended for use. If the unit does not come up to speed within five seconds, turn off the switch. Place an inlet plug assembly in one of the openings in the 3-way inlet and try starting the unit again. After the unit is running, you can remove the inlet plug.

If the Dust Collector still fails to come up to speed immediately, more than likely your shop wiring is too far from your electrical entrance box or if you're using an extension cord, the wire gauge is too small.

Circuit - Before you plug in your Dust Collector, check the output and the amperage of the circuit you'll be using. The output of the circuit must meet or exceed the electrical requirements of the Dust Collector power plant. The amperage must be rated high enough to handle the load (in amps) of that motor, plus any other tools or appliances you may have plugged into the same circuit and running at the same time.

- **The Shopsmith Dust Collector 115-volt motor** is rated at 1-1/2 hp and draws 9.2 amps. This motor runs on ordinary U.S. house current - 115 volts, 60 cycles (hz). The circuit you use should be rated for **at least 15 amps**.
- If you have fuses, we recommend you install "slow-blow" fuses. Fusetron T-15 is recommended. When you first turn on the machine, for a brief instant the motor pulls 5-6 times its usual amperage to get up to running speed.
- If you need to run a new circuit to operate the Dust Collector, be sure that the wire you use is rated to handle the amperage of the circuit.

Grounding - The circuit you use should be properly grounded to protect you from electrical shock.

- The plug on the Shopsmith Dust Collector has three prongs, as shown in Figure 1. The receptacle should have three corresponding holes.

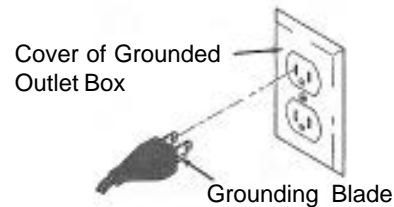

Figure 1

- Do not modify the plug. If it will not fit the outlet, have the proper outlet installed.
- If you have a two-hole receptacle, use a **temporary** adapter to plug in the Dust Collector. (See Figure 2.) The grounding lug or wire on the adapter **MUST** be connected to a permanent ground such as a grounded outlet box. The temporary adapter should be used only **until** a properly grounded outlet can be installed. (**Adapters are not allowed in Canada.**)
- If you are unsure as to whether your outlet box is grounded ask a licensed electrician.



Figure 2

Extension Cords - If you use an extension cord to plug in your Dust Collector, be sure it's a three-conductor cord with a grounding plug and receptacle.

- The wire gauge must be thick enough to prevent loss of power and overheating - the longer the cord, the thicker the wire should be. Use only 12 gauge, 3-wire cord or heavier.
- Before using an extension cord, inspect it for loose wires or damaged insulation. **Replace damaged cords immediately, and only replace with Shopsmith approved parts.**
- Don't let the connection between the power cord and an extension cord lie on a damp or wet surface.

General Information

Terms to Know

The main parts of the Dust Collector are:

1. **Bag** - A heavy duty, disposable, 4 mil., clear plastic bag.
2. **3-Way Inlet** - Allows the hookup of one 2-1/2" diameter hose, or you can use two or three hoses simultaneously.
3. **Filter Hood** - Filters dust particles out of the air and returns dust-free air to the room. An adjustable retaining strap secures it to the main housing.
4. **Rear Handle** - Easily accessible for movement of the unit.
5. **Power Switch** - A rocker type on/off switch with an internal dust seal for extra safety.
6. **Main Housing Assembly** - Contains the motor and blower assembly.
7. **Bag Clips** - Three clips hold the bag while the retaining strap is being attached.
8. **Retaining Strap** - Secures the bag to the main housing.
9. **Base Pan** - Supports the unit. Two front casters and two rear wheels are attached for easy mobility.

Dust Collector Attachment Kit:

10. **Hose (1)** - Connects to the 3-way inlet.
11. **Inlet Plug Assemblies (2)** - Placed in the 3-way inlet port(s) that are not in use.

Specifications:

Bag:	30 gallon capacity
Motor:	1-1/2 hp industrial-duty capacitor start
Power Cord:	12' long
Airflow:	600 cfm
Dimensions:	21" w x 26" l x 48" h
Weight:	Approximately 68 pounds

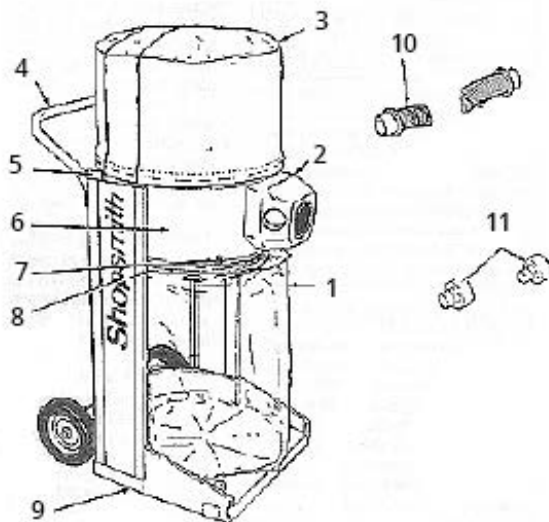

Figure 3

Assembly

Assemble the Dust Collector according to the following procedures. The numbers in parentheses are reference numbers listed in the Parts List.

Tools Required:

- Medium and large Phillips screwdrivers
- Large slot screwdriver or 5/16" nut driver
- Rubber mallet (or block of wood)
- Adjustable wrench, or 7/16" and 1/2" wrenches
- 1/2" socket, 9/16" socket, ratchet wrench, and short extension
- Pliers
- Marking Pen

Install the Legs

1. Lay the main housing (5) on its side. Make sure it's on top of cardboard to prevent scratching. Point the smaller diameter end toward you and the 3-way inlet towards the right with wires pointed up. Place a block of wood or a book under the housing so it doesn't roll. (See Figure 4).



Figure 4: Lay the Main Housing on its side.

2. Locate the three holes on the top of the housing. Position the right leg (36) over the three holes, making sure the narrower side of the leg faces the front toward the 3-way inlet. (See Figure 5). Attach the right leg to the housing with screws (40), lock washers (41) and nuts (42), starting at the top hole. Hand tighten all three nuts.



Figure 5: Support the left leg as you attach it to the Main Housing. The narrower side faces toward the front (3-hose inlet) side.

3. Turn the housing over on the opposite side, then attach the left leg (38) to the housing in the same manner described above. When you have completed installing both legs, the registration mark (®) after the word "Shopsmith" on the legs should be near the larger diameter end (top) of the main housing. Also, the narrower side of both legs should be on the same side of the housing as the 3-way inlet.

Install the Base Pan

NOTE: The procedure below shows inserting the screws through the legs and into the base pan. Then adding the lock washers and nuts on the inside of the base pan. This is the easiest way to install and tighten the hardware. Although uncommon, some customers have had the nuts snag the bag and tear it when full. This is a rare occurrence, but if you want to avoid the possibility, the screw can be inserted through the base and into the leg with the lock washer and nut inside the leg. To tighten the nut you must use a 1/2" socket that will slip through the assembly holes in the legs.

4. With the main housing and assembled legs still on its side, position the base pan (46) between the legs, so that the straight, open side faces toward the front (the side with the 3-way inlet).
5. Attach the legs to the base pan (46) with four screws (40), lock washers (41) and nuts (42). Hand tighten all fasteners.



Figure 6: With the housing on its side, position the base pan so the straight side faces towards the front.

Install the Rear Wheels

6. The Base (46) comes with the Wheel Shaft (45) pre-installed. Lay a 2 x 4 under the end of the Wheel Shaft (45). With the Dust Collector still on its side, slip the first Rear Wheel, flat side up, on the Wheel Shaft end and tap the Wheel onto the Wheel Shaft with your rubber mallet. (Figure 6).
7. Place a Wheel Retainer (43) in the open end of the 9/16" socket (Figure 7). This socket will support the Wheel Retainer while the Retainer is tapped on the Wheel Shaft. Center this socket with Retainer directly over the Shaft, protruding from the center of the Wheel (Figure 8). Strike the socket with the mallet to drive the Retainer on to the Wheel Shaft.
8. Turn the Dust Collector over. Be careful not to pinch the wires. Follow the above procedure to install the second wheel.
9. Set the unit upright.



Figure 7: Place the Wheel Retainer inside a 9/16" socket.



Figure 8: Drive Wheel Retainer on to the Wheel Shaft with a mallet.

Tighten the Leg Screws

- Using a 1/2" socket and ratchet wrench to hold the nuts (42), tighten the leg screws (40) securely with a large Phillips screwdriver.

Attach the Rear Handle

- Attach the Rear Handle (32) to the back the Legs with the Hex Bolt (30) and Lock Washer (31). Use the holes closest to the bend in the Handle only.

Tighten the Rear Handle Screws

- Both ends of the Handle are hollow. The spacer (54) reinforces this hollow ends of the Handle. To install the Spacer, align the Spacer hole with the Handle hole. (Figure 9). Slide the Spacer in the Handle then slide the Hex Bolt with Lock Washer through both the handle and the spacer then thread the Hex Bolt into the Leg and tighten securely with the 7/16" wrench or socket (Figure 10).



Figure 9: Align Spacer hole with Rear Handle hole.



Figure 10: Tighten Rear Handle & Spacer securely into the Leg with Hex Bolt.

Install Snap-in Plugs and Left Leg Cap

- Insert the snap-in plugs (39) into the four round holes in the side of each leg. Tap in place with a mallet. Insert the left leg cap (37) into the top of the left leg. Tap in place with a mallet.

Install Filter Hood

- Slide the round end of the 1/2" wide, Silver Strap (2) through the Hem of the Filter Hood (1). Slide it around the Filter Hood it slides out the second slot in the Filter Hood and the Clamp (4) is against the first slit. (Figure 11)

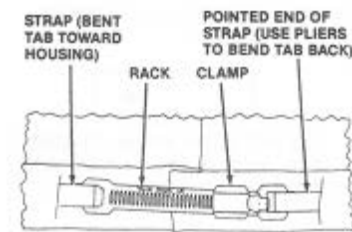

Figure 11: Install the hood retaining strap, rack and clamp. Feed strap through the hem in the filter hood.

- Make sure the writing on the Rack (3) is facing out and up. Slide the Rack into the slot of the Clamp (4). Use a Large flat blade screwdriver or 5/26" Nut Driver to begin to tighten the Clamp on the Rack.
- Install the Filter Hood on the Main Housing. Tighten the Clamp with the slot screwdriver or nut Driver. As you do, make sure the strap tightens between the two ribs on the top of the Main Housing (5) (Figure 12).



Figure 12: Tighten the Clamp & Rack between the two ribs on the top of the Main Housing.

17. Install the filter hood (1) over the main housing (5) so that the hemmed bottom of the filter hood (containing the metal strap you just installed) fits between the two rolled ribs of the housing. Turn the filter hood so the strap clamp is centered at the back of the housing and the Shopsmith Logo on the front of the filter hood is centered with the 3-Way Inlet in front.

Note

Be sure you tighten the strap between the two ribs on the main housing. If the strap is tightened over a rib, the filter hood will loosen and blow off the Dust Collector.

Install Bag

Note

The bag is taller than the bottom opening of the Dust Collector. This extra-tall bag gives you extra room in case you over-fill your Dust Collector and to allow for fully closing the bag with the wire tie.

20. Pick up the 1" wide, dark metal strap (28). Make it into a loop and insert the Rack into the Clamp. Use the large slot screwdriver or 5/16" nut driver to tighten the Clamp until the end of the rack sticks out from under the Clamp nut slightly. Make sure the strap will fit over the bottom of the Main Housing (5).
21. Lay the Bag (29) inside the Strap and open the Bag over the Strap. Fold the open end of the Bag over the Strap, one-third from the top, over the Strap. Slide the Strap with the Bag over the lower rib on the Main Housing (Figure 13). With the large flat screwdriver or 5/16" Nut driver handy, slide the strap with the bag up, over the bottom of the Main Housing.

(cont.) Tighten the Clamp just enough to hold strap on the Main Housing and still allow bag adjustment. Make sure the strap is above the rib on the Main Housing all the way around.



Figure 13: With Bag Retention Strap in place, slide collection bag over the lower rib on the Main Housing.

Hook Up the Dust Collector



Figure 14: Connect the male end of the plug from the Main Housing into the female receptacle on the leg.



Figure 15: Feed the second black wire with two leads through the hole near the plug.

Hook Up the Dust Collector

23. Plug the male socket trailing from the back of the housing into the female socket located on the leg. You will hear a “click” when they are properly seated. (Figure 14)
24. Feed the second black wire, with two leads, from the Main Housing through the bolt hole just below the plug just connected. (Figure 15) Locate the white capacitor (18D) packed in the Hardware bag. It also has two leads with mating connectors to the wire just slipped through the hole in the leg below the plug. Plug either lead of the Capacitor into either lead of the wire. Peel off the protective paper from the tape on the Capacitor and stick it to the inside of the leg. (Figure 16) Be sure there is a little slack in the wires before sticking the Capacitor to the inside of the Leg.
25. Set Dust Collector Upright. Place the Dust Collector behind power equipment. Connect however many hoses you are going to be using to the 3-way inlet (24A) and to the dust chute(s) on power equipment.
26. For each inlet you are not currently using, push an inlet plug (48) with a cap (49) into the open inlet.
27. Plug the Dust Collector into a wall socket. Refer to the section, “Electrical Requirements.”



Figure 16: Plug Capacitor leads into mating connectors in the Leg.

Using the Dust Collector

What NOT to Pick Up

The Dust Collector will help you keep a virtually dust-free workshop. You'll breathe less dust, have a cleaner and safer shop, and eliminate the tracking of dust and shavings to other areas.

When the Dust Collector is attached to wood-working equipment by the hoses, there is no occasion for large scraps to be sucked into the blower. However, when sweeping the floor and cleaning up, pick up large wood scraps before you use the dust collector.

Remember that all materials picked up will pass through the hoses and be sucked toward the fan. There is a fan guard that will allow normal wood dust and shavings to pass through but will stop blocks of wood and rags from entering the fan. Picking up blocks of wood, shop rags, or similar items will clog the Dust Collector.

Hoses

The hoses attach to stationary or handheld power woodworking equipment with 2-1/4" dust chute outlets. An optional reducer allows you to connect to equipment with 1-1/4" chutes such as the Shopsmith Mark V Model 500 (having a serial number 222396 or lower). Three 2-1/2" diameter hoses can be connected to the 3-way inlet and used simultaneously. The large airflow and filter capacity make it suitable for other dust producing activities such as dry-wall sanding, tearing out ceilings, and more.

Filter the Air - You can use the Dust Collector to filter dust from the air in your workshop by removing the hoses and any inlet plugs.

Caring for Your Dust Collector

Your Dust Collector is designed to deliver years of reliable service with a minimum of maintenance.

Cleaning the Filter Hood

During operation, dust will build up on the inside surface of the filter hood. Every time the bag is changed, tap the top and sides of the filter hood to dislodge the dust buildup. If you're generating a lot of fine dust, tap off the dust buildup more often.

If you desire, you can wash the filter hood when it becomes soiled and/or clogged. Before washing, dislodge the dust buildup and remove the retaining strap. Then hand or machine wash the hood in cold water using a mild detergent. Line dry or tumble dry on no heat. When hood is dry, reinstall the retaining strap assembly.

Cleaning the Exterior

As needed, clean the outside of the Dust Collector with a sponge or cloth slightly dampened with a soap and water solution. Wipe or air dry all parts thoroughly.

WARNING

Turn off and unplug the Dust Collector before you begin any maintenance or troubleshooting task.

WARNING

Do not allow water to enter the switch area or to drip through the filter hood.

Troubleshooting Guide

Dust Collector problems usually have simple solutions. Under normal use, you should rarely have to service your Dust Collector. Most problems can be corrected by maintenance or a change of work habits.

Maintenance and Troubleshooting

Problem	Probable Cause	Solution
Unit Will Not Start	Plug Loose in Outlet	Check Plug and Outlet
	Defective Switch	Replace Switch
	Defective Motor	Replace Motor
	Tripped Circuit Breaker or Blown Fuse	Reset Circuit Breaker or Replace Fuse
	Long Extension Cord, Insufficient Wiring, or Dust Collection Plugged into Same Circuit as MARK 7/MV or other Shop Equipment	Refer to "Electrical Requirements" in the Safety Section of this Manual
	Capacitor Blown or Disconnected	Reconnect or Replace Capacitor
Motor Runs Slowly	Capacitor Blown or Disconnected	Reconnect or Replace Capacitor
Motor Stops and Starts Erratically	Electrical Short in Cord	Replace Power Cord
	Electrical Short in Switch	Replace Switch
	Plug Loose in Outlet	Check Plug and Outlet
Dust Blowing Out Around Filter Hood or Bag	Loose Retaining Strap	Tighten Retaining Strap
Loss of Airflow	Filter Hood Clogged	Dislodge Dust Buildup
	Clogged Hoses, Extension Wands, or other Attachments	Unplug Affected Part(s)
	Clogged Inlet	Remove the Screws (4) Holding Logo Plate on 3-Way Inlet & Remove the Screws (4) Holding the 3-Way Inlet in Place. Dislodge any Dust Buildup or Clog & Replace Parts
Filter Hood or Collection Bag Blows Off Main Housing When Dust Collector is Running	Strap is Tightened on Top of Rib on Main Housing	For Filter Hood: Tighten Strap Between Ribs For Collection Bag: Tighten Strap on Flat Area Between Rib & Main Housing

NOTE

If you have any questions about your Shopsmith DC-6000, please call our Customer Service Department at (937)890-5197, send us an e-mail at customerservice@shopsmith.com, or visit our website at www.shopsmith.com.

When you contact us, please tell us your Customer Number and Date Code of your equipment. (Your customer number appears on the invoice/packing slip. The date code is located on the serial label sticker on your machine). To keep them handy, please write in the allotted spaces below.

Customer No: _____

Date Code: _____

